

## DATASHEET

<b>Product</b>	Filter Assembly	<b>Part number</b>	800270010
<b>Document version</b>	1.0	<b>Document status</b>	Release
<b>Notes</b>			

## PRODUCT DESCRIPTION

The NXL-100S Advanced Tunnel Horn is equipped with a filter unit to protect against the ingress of dust and moisture. Regular cleaning of this filter is required. In case of time-critical maintenance, it is advised to replace the complete filter assembly.

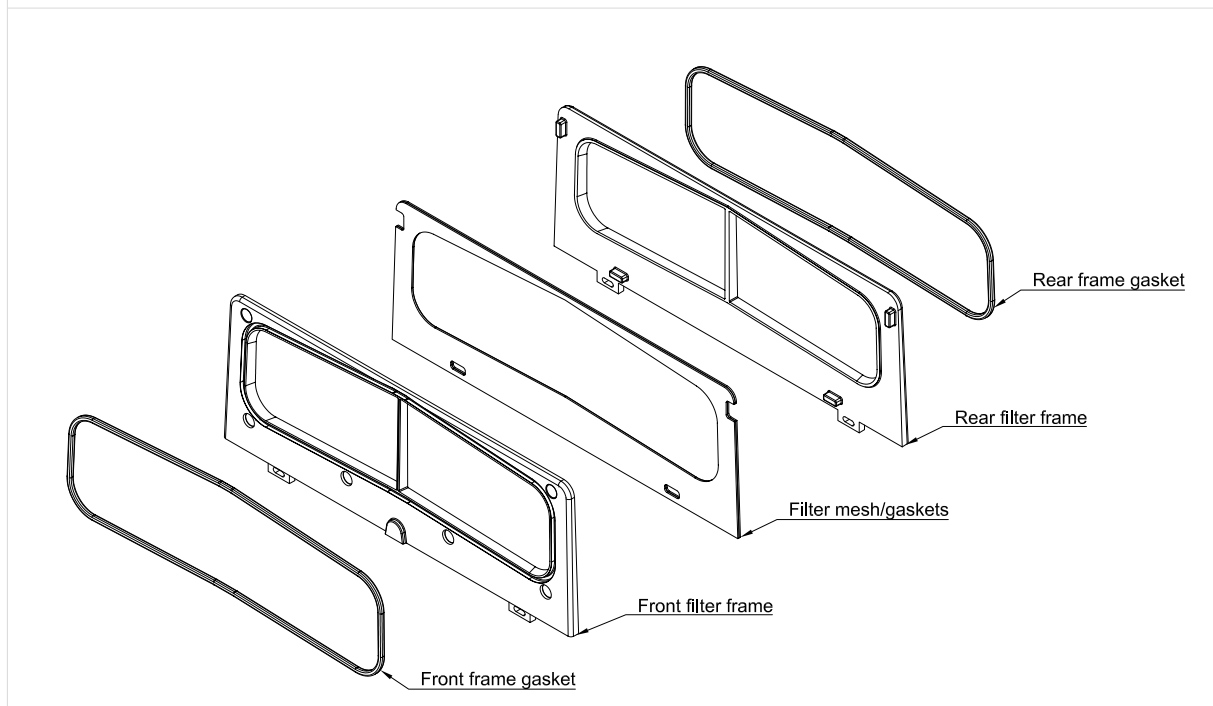

## FEATURES

<b>Application</b>	Replacement part for time-critical filter maintenance.
<b>Compatibility</b>	Standard NXL-100S total filter assembly.
<b>Functionality</b>	Provides effective protection while maintaining a low acoustical insertion loss, ensuring optimal performance of the NXL-100S.
<b>Purpose</b>	The purpose of this filter is to prevent dust and moisture ingress during normal operating conditions of the NXL-100S.
<b>Material</b>	Flame-retardant thermoplastic frames with neodymium magnets and elastomer gaskets. Coated stainless steel mesh with Neoprene/CR closed-cell rubber gaskets.

## TECHNICAL SPECIFICATIONS

### MECHANICAL

Dimensions (Width x Height x Thickness)	260 x 101 x 16 mm	
Weight	165 grams	
Material	Frames	Flame-Retardant Thermoplastic
	Magnets	Epoxy-coated neodymium
	Frame gaskets	Elastomer
	Mesh	Coated stainless steel
	Mesh gaskets	Neoprene closed-cell rubber
Color	Frames	Black
	Magnets	Black
	Frame gaskets	Red
	Mesh	Green
	Mesh gaskets	Black
Temperature Range (ambient)	-25 to 70 °C	

### DRAWINGS

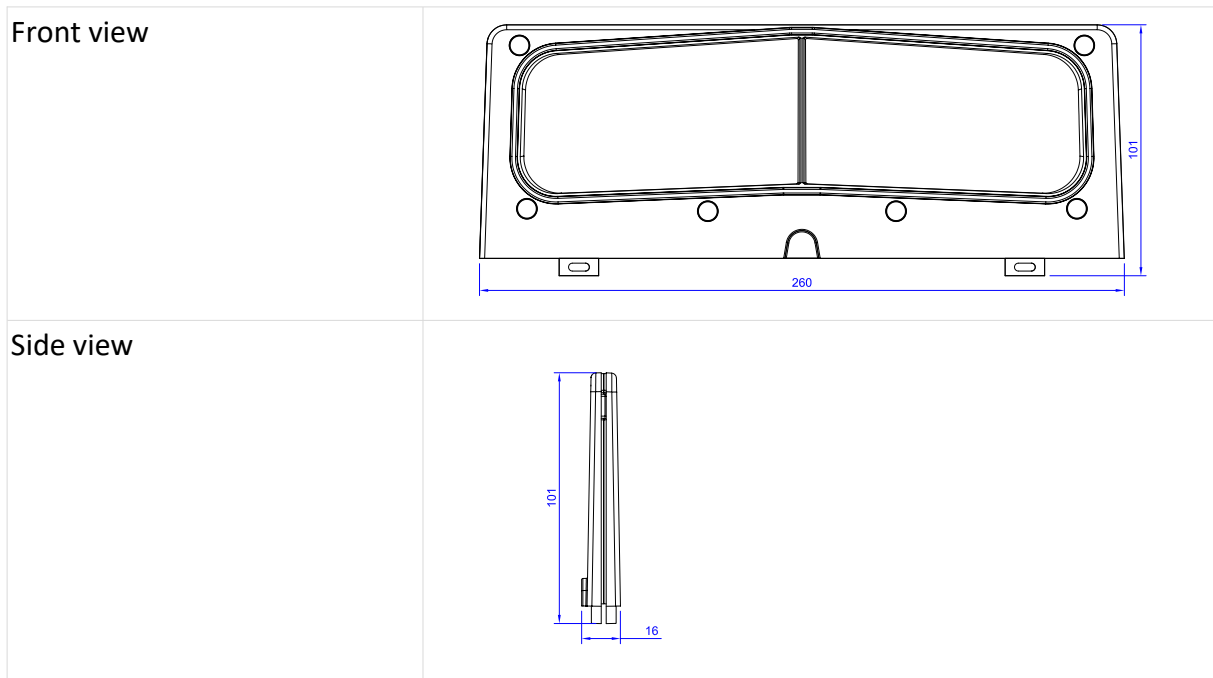

## DOCUMENT REVISION

---

1.0	15-10-2024	Start version.
-----	------------	----------------



NXD-Audio B.V.  
Koxkampseweg 10  
5301 KK Zaltbommel  
The Netherlands

