

DATASHEET

Product	Cleaning Filter Mylar	Part number	800270045
Document version	1.1	Document status	Release
Notes			

PRODUCT DESCRIPTION

This Cleaning Filter ensures the integrity of the NXL-100S Advanced Tunnel Horn Loudspeaker during high-pressure cleaning, providing effective protection against water ingress.

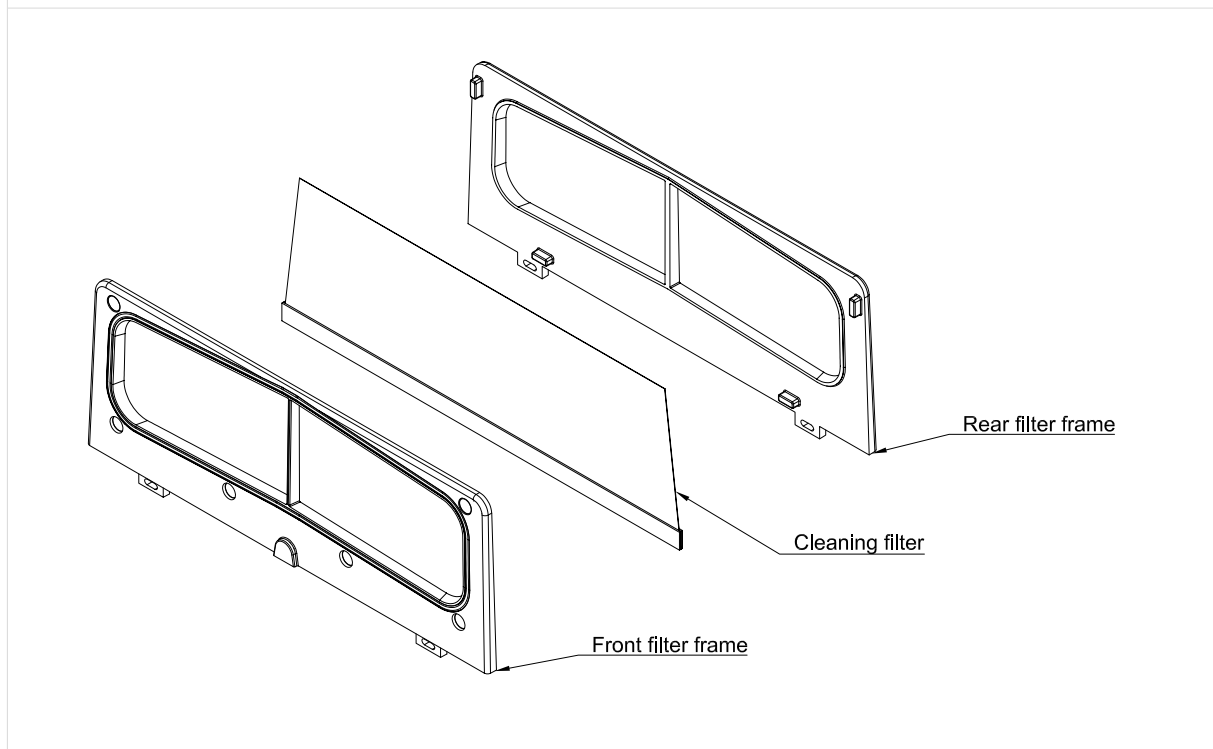

FEATURES

Application	To be used in conjunction with the Cleaning Filter Cover during high-pressure cleaning of the NXL-100S Advanced Tunnel Horn Loudspeaker.
Compatibility	Designed for use with the standard NXL-100S front and rear filter frames.
Functionality	During high-pressure cleaning, the default filter of the NXL-100S should be replaced by this non-permeable filter.
Purpose	The purpose of this filter is to prevent water ingress during cleaning of the NXL-100S.
Material	Constructed from a Mylar/polyester sheet with Neoprene/CR closed-cell rubber gaskets.

TECHNICAL SPECIFICATIONS

MECHANICAL

Dimensions (Width x Height x Thickness)		258 x 85 x 2 mm
Weight		7 grams
Material	Sheet	Mylar Type A
	Gasket	Neoprene closed-cell rubber
Color	Sheet	Milky White Translucent
	Gasket	Black
Temperature Range (ambient)		-25 to 70 °C

DRAWINGS

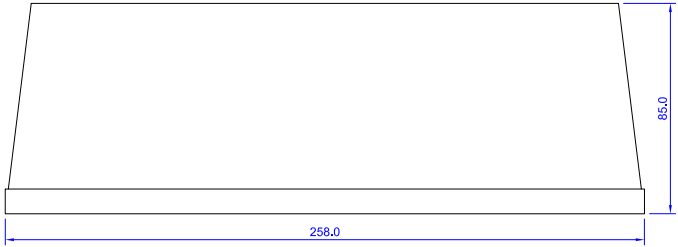
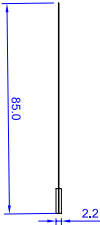
<p>Front view</p>	
<p>Side view</p>	

DOCUMENT REVISION

1.0	23-07-2024	Start version.
1.1	17-09-2024	Correction 3D drawing.



NXD-Audio B.V.
Koxkampseweg 10
5301 KK Zaltbommel
The Netherlands

