

DATASHEET

Product	Cleaning Filter Cover	Part number	330100210
Document version	1.0	Document status	Release
Notes			

PRODUCT DESCRIPTION

The Cleaning Filter Cover provides effective protection against water ingress during high-pressure cleaning, enhancing maintenance efficiency and longevity of the NXL-100S Advanced Tunnel Horn Loudspeaker.

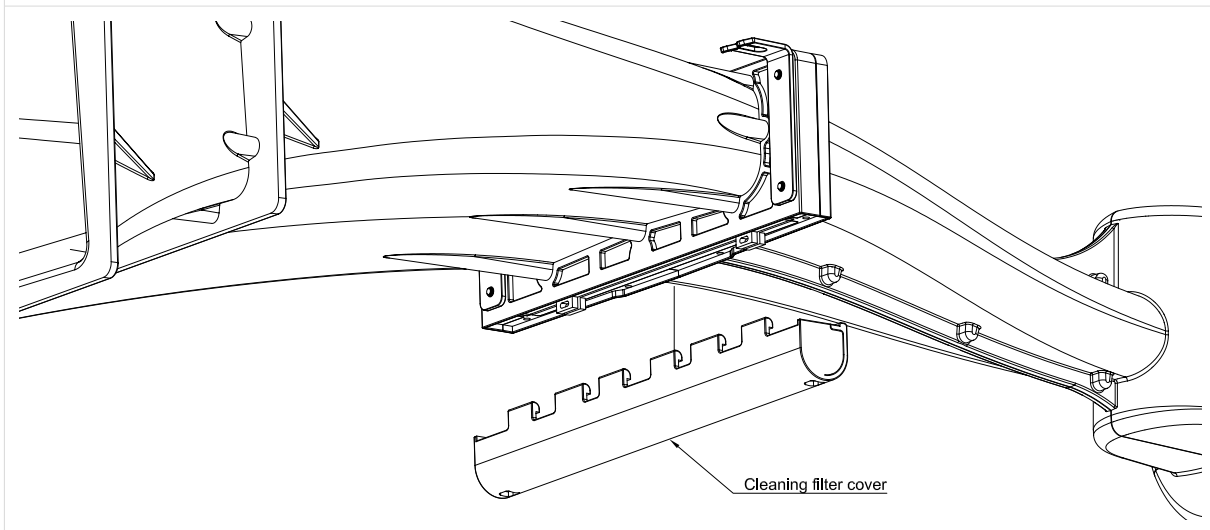

FEATURES

Application	To be installed in conjunction with the Cleaning Filter during high-pressure cleaning of the NXL-100S Advanced Tunnel Horn Loudspeaker.
Design	Features a snap-on design for easy installation and removal, eliminating the need for screws and enhancing water ingress protection during cleaning.
Functionality	Equipped with multiple grip fingers and two integrated handles for easy attachment and detachment.
Purpose	Prevents water ingress during the cleaning of the NXL-100S, while its off-white color aids in visual inspection, ensuring the cover is not left on the unit after maintenance.
Durability	Using a snap-on design maintains the integrity of the filter cover's screw holes by limiting repetitive screwing, which is beneficial because the cleaning filter cover is only used during maintenance and does not need to use the same screw holes as the standard filter cover.

TECHNICAL SPECIFICATIONS

MECHANICAL

Dimensions (L x W x H)	327 x 56 x 45 mm
Weight	150 grams
Material	SLA resin
Color	Off-white
Temperature Range	-25 to 40 °C

DRAWINGS

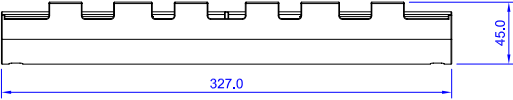
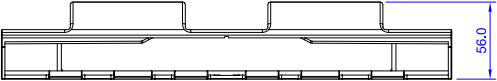
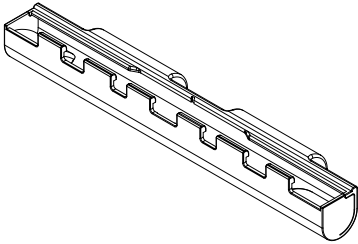
Front view	
Top view	
3D view	

DOCUMENT REVISION

1.0	23-07-2024	Start version.
-----	------------	----------------



NXD-Audio B.V.
Koxkampseweg 10
5301 KK Zaltbommel
The Netherlands

